

Mirabilis Design Adds System-Level Modelling Support for Industry-Standard Arteris FlexNoC and Ncore Network-on-Chip IPs

Mirabilis Design announced today the latest addition to the VisualSim Architect with modelling support for Arteris' FlexNoC and Ncore Network-on-Chip (NoC) IPs.

SANTA CLARA, CA, UNITED STATES, February 4, 2025 /EINPresswire.com/ -- [Mirabilis Design](#) Adds System-Level Modelling Support for Industry-Standard [Arteris](#) FlexNoC and Ncore Network-on-Chip IPs

Mirabilis Design announced today the latest addition to the [VisualSim Architect](#) with modelling support for Arteris' FlexNoC and Ncore Network-on-Chip (NoC) IPs. This addresses the long-standing demand from customers to model this best-in-class interconnect technology, enabling full System-on-Chip modelling support for exploration across AI, datacenter and edge applications. The NoC System-Level IP Library bridges the gap between requirements management and micro-architecture SystemC models, providing an exploration platform.

Designers and researchers can use this modelling library to experiment with different topologies, coherent cache hierarchy strategies, assignment of initiators and targets onto network nodes, and define the NoC settings including flit size, buffer depths, Quality-of-

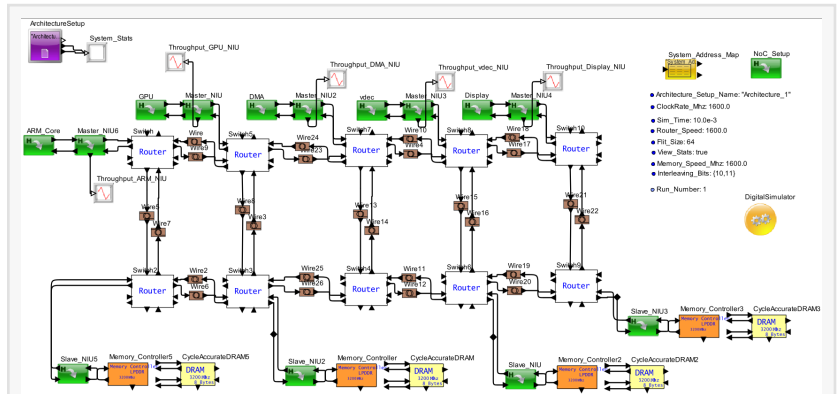

Arteris NoC

Arteris Parameters

Statistic	Value
Arteris_NoC_R1_2_to_R2_2_Throughput_Bps	= 9.5872000095872E6
Arteris_NoC_R1_3_Throughput_MBps	= 24.1043090820312
Arteris_NoC_R1_3_Utilization_Pct	= 0.4723125
Arteris_NoC_R1_3_to_R1_2_Throughput_Bps	= 6.1008000061008E6
Arteris_NoC_R1_3_to_R2_2_Throughput_Bps	= 9.5872000095872E6
Arteris_NoC_R1_4_Throughput_MBps	= 28.3767700195312
Arteris_NoC_R1_4_Utilization_Pct	= 0.569887500001
Arteris_NoC_R1_4_to_R1_3_Throughput_Bps	= 1.0580800010581E7
Arteris_NoC_R1_4_to_R2_2_Throughput_Bps	= 9.5872000095872E6
Arteris_NoC_R1_5_Throughput_MBps	= 19.720485084375
Arteris_NoC_R1_5_Utilization_Pct	= 0.378112499999
Arteris_NoC_R1_5_to_R1_4_Throughput_Bps	= 7.8912000078912E6
Arteris_NoC_R2_1_Throughput_MBps	= 6.3936000063936E6
Arteris_NoC_R2_1_Throughput_MBps	= 19.972290039062
Arteris_NoC_R2_1_Utilization_Pct	= 0.3621198100003
Arteris_NoC_R2_1_to_R1_1_Throughput_Bps	= 587200.0005872
Arteris_NoC_R2_1_to_R2_2_Throughput_Bps	= 1.0788800010789E7
Arteris_NoC_R2_2_Throughput_MBps	= 40.956115726562
Arteris_NoC_R2_2_Utilization_Pct	= 0.6748327499998
Arteris_NoC_R2_2_to_R1_2_Throughput_Bps	= 5.296000005296E6
Arteris_NoC_R2_2_to_R1_3_Throughput_Bps	= 6.9792000089792E6
Arteris_NoC_R2_2_to_R2_2_Throughput_Bps	= 1.9227200019227E7
Arteris_NoC_R2_3_Throughput_MBps	= 35.1272583007812
Arteris_NoC_R2_3_Utilization_Pct	= 0.5646874999999
Arteris_NoC_R2_3_to_R1_3_Throughput_Bps	= 5.1072000051072E6
Arteris_NoC_R2_3_to_R2_2_Throughput_Bps	= 1.3126400013126E7
Arteris_NoC_R2_3_to_R2_4_Throughput_Bps	= 1.86000000186E7
Arteris_NoC_R2_4_Throughput_MBps	= 39.730849009375
Arteris_NoC_R2_4_Utilization_Pct	= 0.6326919400002
Arteris_NoC_R2_4_to_R1_4_Throughput_Bps	= 1.2276800012277E7
Arteris_NoC_R2_4_to_R2_3_Throughput_Bps	= 8.0152000080152E6
Arteris_NoC_R2_4_to_R2_5_Throughput_Bps	= 1.2499200012499E7
Arteris_NoC_R2_5_Throughput_MBps	= 27.24609375
Arteris_NoC_R2_5_Utilization_Pct	= 0.4981648800008
Arteris_NoC_R2_5_to_R1_5_Throughput_Bps	= 1.4248400014285E7
Arteris_NoC_R2_5_to_R2_4_Throughput_Bps	= 4.608000004608E6

Arteris Statistics

Service algorithms, and clock speeds. The optimized architecture can be entered into Arteris' IP configuration tools to generate the RTL. The library comes packaged with a variety of parameters to configure the IP, a report generator to capture and display statistics, and a library of application-specific workloads.

"The partnership between Mirabilis Design and Arteris represents a transformative step in high-performance SoC innovation. The integration of Arteris' industry-leading NoC with processors, AI engines, GPUs, coherent caches, DDR/LPDDR DRAM, and peripherals, delivers scalable, efficient, and optimized solutions for cutting-edge applications.", said Deepak Shankar, Founder of Mirabilis Design.

"Architects now have access to a powerful platform that accelerates design exploration and ensures precise trade-offs for power, performance, and functionality-driving the future of advanced computing." "We believe that integrating Arteris' FlexNoC and Ncore models into Mirabilis Design's VisualSim Architect will help our mutual customers," said Guillaume Boillet, senior director of strategic marketing at Arteris. "Our partnership helps system designers to more effectively model and simulate real-world SoC workloads and make critical architecture-level trade-offs that account for the NoCs"

Availability: The VisualSim System-Level NoC library with the Arteris FlexNoC and Ncore system models is available now in VisualSim Architect version 2420 on Linux, Windows, and Mac.

About Mirabilis Design Inc.

Mirabilis Design is a Silicon Valley software company, providing software and training solutions to identify and eliminate risk in the product specification, accurately predicting the human and time resources required to develop the product, and improve communication between diverse engineering teams. VisualSim Architect combines Intellectual Property, system-level modelling, simulation, environment analysis and application templates to significantly improve model construction, simulation, analysis, and RTL verification. The environment enables designers to rapidly converge to a design which meets a diverse set of interdependent time and power requirements. It is used very early in the design process in parallel with (and as an aid to) the written specification and before an implementation (for example, RTL, software code, or schematic) of the product.

About Arteris

Arteris is a leading provider of system IP for the acceleration of system-on-chip (SoC) development across today's electronic systems. Arteris network-on-chip (NoC) interconnect IP and SoC integration automation technology enable higher product performance with lower power consumption and faster time to market, delivering better SoC economics so its customers can focus on dreaming up what comes next. Learn more at arteris.com.

Deepak Shankar
Mirabilis Design Inc

+1 408-245-8992

dshankar@mirabilisdesign.com

This press release can be viewed online at: <https://www.einpresswire.com/article/782915394>

EIN Presswire's priority is source transparency. We do not allow opaque clients, and our editors try to be careful about weeding out false and misleading content. As a user, if you see something we have missed, please do bring it to our attention. Your help is welcome. EIN Presswire, Everyone's Internet News Presswire™, tries to define some of the boundaries that are reasonable in today's world. Please see our Editorial Guidelines for more information.

© 1995-2025 Newsmatics Inc. All Right Reserved.